

Алматы (7273)495-231	Калининград (4012)72-03-81	Омск (3812)21-46-40	
Ангарск (3955)60-70-56	Калуга (4842)92-23-67	Орел (4862)44-53-42	
Архангельск (8182)63-90-72	Кемерово (3842)65-04-62	Оренбург (3532)37-68-04	Сыктывкар (8212)25-95-17
Астрахань (8512)99-46-04	Киров (8332)68-02-04	Пенза (8412)22-31-16	Тамбов (4752)50-40-97
Барнаул (3852)73-04-60	Коломна (4966)23-41-49	Петрозаводск (8142)55-98-37	Тверь (4822)63-31-35
Белгород (4722)40-23-64	Кострома (4942)77-07-48	Псков (8112)59-10-37	Тольятти (8482)63-91-07
Благовещенск (4162)22-76-07	Краснодар (861)203-40-90	Пермь (342)205-81-47	Томск (3822)98-41-53
Брянск (4832)59-03-52	Красноярск (391)204-63-61	Ростов-на-Дону (863)308-18-15	Тула (4872)33-79-87
Владивосток (423)249-28-31	Курск (4712)77-13-04	Рязань (4912)46-61-64	Тюмень (3452)66-21-18
Владикавказ (8672)28-90-48	Курган (3522)50-90-47	Самара (846)206-03-16	Ульяновск (8422)24-23-59
Владимир (4922)49-43-18	Липецк (4742)52-20-81	Саранск (8342)22-96-24	Улан-Удэ (3012)59-97-51
Волгоград (844)278-03-48	Магнитогорск (3519)55-03-13	Санкт-Петербург (812)309-46-40	Уфа (347)229-48-12
Вологда (8172)26-41-59	Москва (495)268-04-70	Саратов (845)249-38-78	Хабаровск (4212)92-98-04
Воронеж (473)204-51-73	Мурманск (8152)59-64-93	Севастополь (8692)22-31-93	Чебоксары (8352)28-53-07
Екатеринбург (343)384-55-89	Набережные Челны (8552)20-53-41	Симферополь (3652)67-13-56	Челябинск (351)202-03-61
Иваново (4932)77-34-06	Нижний Новгород (831)429-08-12	Смоленск (4812)29-41-54	Череповец (8202)49-02-64
Ижевск (3412)26-03-58	Новокузнецк (3843)20-46-81	Сочи (862)225-72-31	Чита (3022)38-34-83
Иркутск (395)279-98-46	Новосибирск (3496)41-32-12	Ставрополь (8652)20-65-13	Якутск (4112)23-90-97
Казань (843)206-01-48	Новосибирск (383)227-86-73	Сургут (3462)77-98-35	Ярославль (4852)69-52-93
	Киргизия (996)312-96-26-47	Россия (495)268-04-70	Казахстан (772)734-952-31

Electric Pedestrian Pallet Truck KH.LS 2000

Standard equipment

- Max travel speed - 6,0 km/h
- Capacity - 2000 kg
- Lifting height – 125 mm
- AC drive motor - 1,3 kW:
 - Maintenance free
 - External Encoder
 - Low noise level
- DC pump motor – 2,0 kW
- Speed control by Pulse controller AC/180A, including REGENERATIVE BRAKING with energy reclamation to the battery
- Electronics - modern CANBUS-architecture requiring less wiring, giving better reliability, providing easy and fast diagnostics;
- Horn
- Automatic Braking:
 - EMERGENCY and PARKING electromagnetic brake
 - REGENERATIVE BRAKING when releasing Accelerator in a neutral position or reversing the travel direction
- Traction Battery 24V 2PzS/250Ah C5 / wet PbAcid battery
- High frequency / HF automatic on-board charger 24V/30A 1 ph.
- EMERGENCY Switch
- Multifunctional Digital Indicator displaying:
 - Battery's state of charge
 - Hour meter
 - Alarms
 - 3 factory preselected Driving Modes (SPD HI / SPD MID / SPD LO)
- Battery charge indicator
- Rollers and wheels in POLYURETHANE, load-side - Tandem rollers / as standard
- Two castor wheels, left and right driver-side
- Spring loaded Drive Wheel, mid driver-side
- CREEP SPEED function – traveling in restricted areas with Tiller-arm in upright/vertical position
- Virtually maintenance-free Drive-wheel unit:
 - Modern AC traction motor in vertical position
 - High efficient gear-box / gears in oil bath - no oil change required for life
 - High quality Traction wheel with POLYURETHANE, 93° Shore A tyre (other tyres available on request)
 - High quality Electromagnetic Brake with environment-friendly friction lining

Optional equipment:

- Automatically foldable stand-on Platform, mid driver-side
- Authorised access with PIN Code management
- Traction motor AC 1,5 kW
- Optional batteries:
 - 24V 3PzS/315 Ah C5, incl. charger 24V/45A 1 ph.
 - 24V 3PzS/375 Ah C5, incl. charger 24V/45A 1 ph.
- Maintenance-free batteries HAWKER (GEL or NexSys)
- Li-Ion maintenance-free batteries MIDAC

Electric Pedestrian Pallet Truck KH.LS 2000

Type sheet for industrial Trucks according to VDI 2198

Characteristics	1.1	Manufacturer			VENI
	1.2	Manufacturer's type designation			KH.LS 2000
	1.3	Power unit			Battery
	1.4	Operation			Pedestrian
	1.5	Load capacity	Q	(kg)	2000
	1.6	Load centre	c	(mm)	600
	1.8	Axle centre to fork face	x	(mm)	862(*)
	1.9	Wheelbase	y	(mm)	1320(*)
	Weight	2.1	Service weight incl. battery		(kg)
Wheel/tyres	3.1	Tyres front/rear (Polyurethane/PU, Vulkollan/VU)			PU/PU
	3.2	Tyre size, front		(mm)	D 230x70
	3.3	Tyre size, rear		(mm)	D 85x70
	3.4	Support wheels		(mm)	D 150x50
	3.5	Wheels, number front / rear (x=driven)		(mm)	1x+2/4
	3.6	Track width, front	b ₁₀	(mm)	520
	3.7	Track width, rear	b ₁₁	(mm)	375
Dimensions	4.4	Lift	h ₃	(mm)	125
	4.9	Height of tiller in drive position min./max.	h ₁₄	(mm)	1040/1330
	4.15	Fork height, lowered	h ₁₃	(mm)	85
	4.19	Overall length	l ₁	(mm)	1810
	4.20	Length to fork face	l ₂	(mm)	660
	4.21	Overall width	b ₁	(mm)	736
	4.22	Fork dimensions	s/e/l	(mm)	55/165/1150
	4.25	Overall forks width	b ₅	(mm)	540
	4.32	Ground clearance, centre of wheelbase	m ₂	(mm)	35/160
	4.34	Aisle width with pallet 800x1200 mm along forks	Ast	(mm)	2068
4.35	Turning radius	Wa	(mm)	1530	
Performance	5.1	Travel speed, with/without load		(km/h)	5.6/6.0
	5.2	Lifting speed, with/without load		(m/s)	0.060/0.090
	5.3	Lowering speed, with/without load		(m/s)	0.065/0.050
	5.8	Maximum gradeability, with/without load		(%)	8/16
	5.10	Service brake			Electromagnetic
Drive	6.1	Drive motor, rating S2 60 min		(kW)	1.3
	6.2	Lift motor, rating S3 15%		(kW)	2.0
	6.4	Battery voltage/rated capacity C5		(V/Ah)	24/250
Others	8.1	Type of drive control			Pulse controller
					AC/180A

(*) - Load section lowered +72 mm

KH.LS 2000

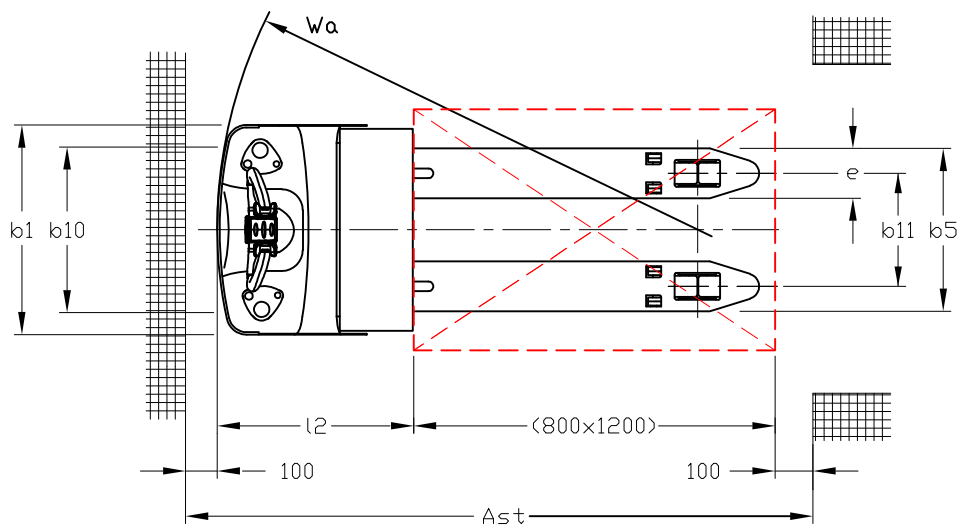
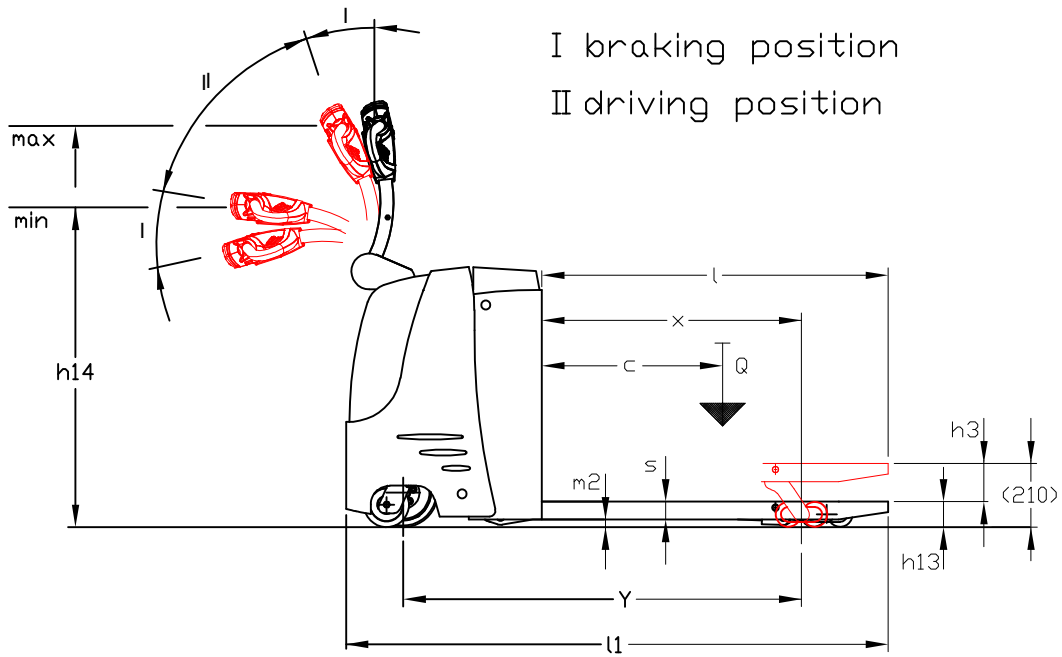

Алматы (7273)495-231
Ангарск (3955)60-70-56
Архангельск (8182)63-90-72
Астрахань (8512)99-46-04
Барнаул (3852)73-04-60
Белгород (4722)40-23-64
Благовещенск (4162)22-76-07
Брянск (4832)59-03-52
Владивосток (423)249-28-31
Владикавказ (8672)28-90-48
Владимир (4922)49-43-18
Волгоград (844)278-03-48
Вологда (8172)26-41-59
Воронеж (473)204-51-73
Екатеринбург (343)384-55-89
Иваново (4932)77-34-06
Ижевск (3412)26-03-58
Иркутск (395)279-98-46
Казань (843)206-01-48

Калининград (4012)72-03-81
Калуга (4842)92-23-67
Кемерово (3842)65-04-62
Киров (8332)68-02-04
Коломна (4966)23-41-49
Кострома (4942)77-07-48
Краснодар (861)203-40-90
Красноярск (391)204-63-61
Курск (4712)77-13-04
Курган (3522)50-90-47
Липецк (4742)52-20-81
Магнитогорск (3519)55-03-13
Москва (495)268-04-70
Мурманск (8152)59-64-93
Набережные Челны (8552)20-53-41
Нижний Новгород (831)429-08-12
Новокузнецк (3843)20-46-81
Ноябрьск (3496)41-32-12
Новосибирск (383)227-86-73
Киргизия (996)312-96-26-47

Омск (3812)21-46-40
Орел (4862)44-53-42
Оренбург (3532)37-68-04
Пенза (8412)22-31-16
Петрозаводск (8142)55-98-37
Псков (8112)59-10-37
Пермь (342)205-81-47
Ростов-на-Дону (863)308-18-15
Рязань (4912)46-61-64
Самара (846)206-03-16
Саранск (8342)22-96-24
Санкт-Петербург (812)309-46-40
Саратов (845)249-38-78
Севастополь (8692)22-31-93
Симферополь (3652)67-13-56
Смоленск (4812)29-41-54
Сочи (862)225-72-31
Ставрополь (8652)20-65-13
Сургут (3462)77-98-35
Россия (495)268-04-70

Сыктывкар (8212)25-95-17
Тамбов (4752)50-40-97
Тверь (4822)63-31-35
Тольятти (8482)63-91-07
Томск (3822)98-41-53
Тула (4872)33-79-87
Тюмень (3452)66-21-18
Ульяновск (8422)24-23-59
Улан-Удэ (3012)59-97-51
Уфа (347)229-48-12
Хабаровск (4212)92-98-04
Чебоксары (8352)28-53-07
Челябинск (351)202-03-61
Череповец (8202)49-02-64
Чита (3022)38-34-83
Якутск (4112)23-90-97
Ярославль (4852)69-52-93
Казахстан (772)734-952-31