

Алматы (7273)495-231	Калининград (4012)72-03-81	Омск (3812)21-46-40	Сыктывкар (8212)25-95-17
Ангарск (3955)60-70-56	Калуга (4842)92-23-67	Орел (4862)44-53-42	Тамбов (4752)50-40-97
Архангельск (8182)63-90-72	Кемерово (3842)65-04-62	Оренбург (3532)37-68-04	Тверь (4822)63-31-35
Астрахань (8512)99-46-04	Киров (8332)68-02-04	Пенза (8412)22-31-16	Тольятти (8482)63-91-07
Барнаул (3852)73-04-60	Коломна (4966)23-41-49	Петрозаводск (8142)55-98-37	Томск (3822)98-41-53
Белгород (4722)40-23-64	Кострома (4942)77-07-48	Псков (8112)59-10-37	Тула (4872)33-79-87
Благовещенск (4162)22-76-07	Краснодар (861)203-40-90	Пермь (342)205-81-47	Тюмень (3452)66-21-18
Благовещенск (4162)22-76-07	Красноярск (391)204-63-61	Ростов-на-Дону (863)308-18-15	Ульяновск (8422)24-23-59
Брянск (4832)59-03-52	Курск (4712)77-13-04	Рязань (4912)46-61-64	Улан-Удэ (3012)59-97-51
Владивосток (423)249-28-31	Курган (3522)50-90-47	Самара (846)206-03-16	Уфа (347)229-48-12
Владикавказ (8672)28-90-48	Липецк (4742)52-20-81	Саранск (8342)22-96-24	Хабаровск (4212)92-98-04
Владимир (4922)49-43-18	Магнитогорск (3519)55-03-13	Санкт-Петербург (812)309-46-40	Чебоксары (8352)28-53-07
Волгоград (844)278-03-48	Москва (495)268-04-70	Саратов (845)249-38-78	Челябинск (351)202-03-61
Вологда (8172)26-41-59	Мурманск (8152)59-64-93	Севастополь (8692)22-31-93	Череповец (8202)49-02-64
Воронеж (473)204-51-73	Набережные Челны (8552)20-53-41	Симферополь (3652)67-13-56	Чита (3022)38-34-83
Екатеринбург (343)384-55-89	Нижний Новгород (831)429-08-12	Смоленск (4812)29-41-54	Якутск (4112)23-90-97
Иваново (4932)77-34-06	Новокузнецк (3843)20-46-81	Сочи (862)225-72-31	Ярославль (4852)69-52-93
Ижевск (3412)26-03-58	Новый Уренгой (3496)41-32-12	Ставрополь (8652)20-65-13	
Иркутск (395)279-98-46	Новосибирск (383)227-86-73	Сургут (3462)77-98-35	
Казань (843)206-01-48	Киргизия (996)312-96-26-47	Россия (495)268-04-70	Казахстан (772)734-952-31

Electric Pedestrian Pallet Stacker KM.AC 1200/2,0

Standard equipment:

- Max. travel speed – 6,0 km/h
- Capacity – 1200 kg
- Lifting height – 2,0 m
- AC Drive motor - 1,3 kW
 - Maintenance free
 - External Encoder
 - Low noise level
- DC Pump motor – 2,2 kW
- Speed control by Pulse Controller COMBI AC/250A including regenerative braking with energy reclamation to the battery
- Electronics - modern CANBUS-architecture requiring less wiring, giving better reliability, providing easy and fast diagnostics
- Horn
- Automatic Braking:
 - EMERGENCY and PARKING electromagnetic brake
 - REGENERATIVE BRAKING when releasing the Accelerator in a neutral position or reversing the travel direction
- Traction battery 24V 2PzS/160Ah C5 (wet Pb Acid batteries)
- High frequency/HF automatic On-board Charger 24V/30A 1 ph.
- EMERGENCY Switch
- Multifunctional Digital Indicator displaying:
 - Battery's state of charge
 - Hour meter
 - Alarms
 - 3 factory preselected Driving Modes (SPD HI / SPD MID / SPD LO)
 - 3 factory preselected Lifting/Lowering Modes (HYD SFT / HYD MID / HYD HRD)
- Battery charge indicator
- Proportional hydraulics for smooth, step-less Lifting/Lowering speed control
- Rollers and wheels in Polyurethane. Load side - Single rollers / as standard
- Rigidly fixed Drive Wheel/left Driver's side and Castor wheel D150x50/right Driver's side
- CREEP SPEED function – travelling in restricted areas with Tiller-arm in upright position/vertical
- Automatic Travel speed reduction when forks raised above 600mm in accordance with the EN 1726-2 requirements
- Two-stage mast with central cylinder
- Virtually maintenance-free Drive-wheel unit:
 - Modern AC traction motor in vertical position
 - High efficient gear box /gears in oil bath - no oil change required for life
 - High quality Traction wheel with Polyurethane, 93° Shore A tyre (other tyres available on request)
 - High quality Electromagnetic Brake with environment-friendly friction lining.

Optional equipment:

- Tandem rollers
- Authorised access with PIN Code management
- Batteries with higher capacity:
 - 24V 2PzS/180 Ah C5
 - 24V 2PzS/250 Ah C5
- Package EPS/Electric Powered Steering (including - EPS Transmission 1,3 kW + Mechanical Interface + Steering Controller + Sensors + Wiring + Integration)
Note: EPS is a system to provide FATIGUE-FREE (thus driver-friendly) and safe steering by means of electrical front-axle steering and Curve control
- Maintenance-free batteries HAWKER (GEL or NexSys)
- Li-Ion maintenance-free batteries MIDAC

Electric Pedestrian Pallet Stacker KM.AC 1200/2,0

Type sheet for industrial Trucks according to VDI 2198

Characteristics	1.1	Manufacturer			VENI
	1.2	Manufacturer's type designation			KM.AC 1200/2,0
	1.3	Power unit			Battery
	1.4	Operation			Pedestrian
	1.5	Load capacity	Q	(kg)	1200
	1.6	Load centre	c	(mm)	600
	1.8	Axle centre to fork face	x	(mm)	683
	1.9	Wheelbase	y	(mm)	1220
	Weight	2.1	Service weight incl. battery		(kg)
Wheels/tyres	3.1	Tyres front/rear (Polyurethane/PU, Vulkollan/VU)			PU/PU
	3.2	Tyre size, front		(mm)	D 230x70
	3.3	Tyre size, rear		(mm)	D 85x100
	3.4	Support wheel		(mm)	D 150x50
	3.5	Wheels, number front / rear (x=driven)		(mm)	1x+1/2
	3.6	Track width, front	b ₁₀	(mm)	621
	3.7	Track width, rear	b ₁₁	(mm)	410
Dimensions	4.2	Height, mast lowered	h ₁	(mm)	1560
	4.3	Free lift	h ₂	(mm)	120
	4.4	Lift	h ₃	(mm)	1910
	4.5	Height, mast extended	h ₄	(mm)	2455
	4.9	Height of tiller in drive position min./max.	h ₁₄	(mm)	1200/1310
	4.15	Fork height, lowered	h ₁₃	(mm)	90
	4.151	Fork height, lifted	h ₃ +h ₁₃	(mm)	2000
	4.19	Overall length	l ₁	(mm)	1865
	4.20	Length to fork face	l ₂	(mm)	715
	4.21	Overall width	b ₁	(mm)	852
	4.22	Fork dimensions	s/e/l	(mm)	55/165/1150
	4.25	Overall forks width	b ₅	(mm)	570
	4.32	Ground clearance, centre of wheelbase	m ₂	(mm)	30
	4.34	Aisle width with pallet 800x1200 mm along forks	Ast	(mm)	2284
	4.35	Turning radius	Wa	(mm)	1430
Performance	5.1	Travel speed, with/ without load		(km/h)	5.5/6.0
	5.2	Lifting speed, with/ without load		(m/s)	0.142/0.240
	5.3	Lowering speed, with/ without load		(m/s)	0.260/0.290
					-
	5.8	Maximum gradeability, with/ without load		(%)	10/15
	5.10	Service brake			Electromagnetic
Drive	6.1	Drive motor, rating S2 60 min		(kW)	1.3
	6.2	Lift motor rating S3 15%		(kW)	2.2
	6.4	Traction battery voltage/ rated capacity C5		(V/Ah)	24/160
Others	8.1	Type of drive control			Pulse controller COMBI AC/250A

KM.AC 1200/2,0

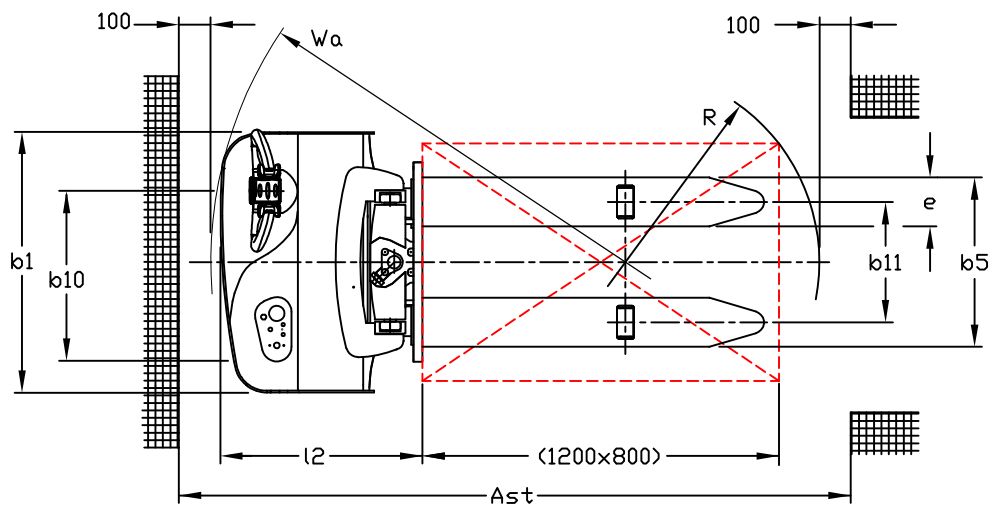
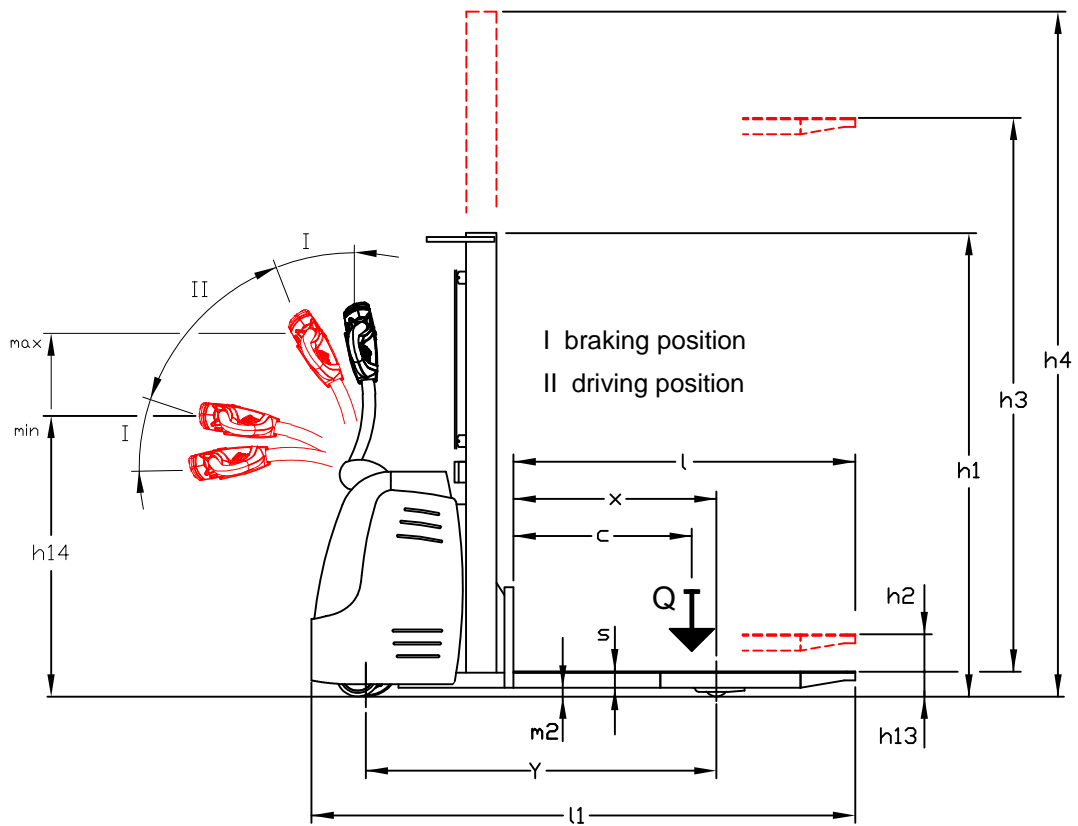

Алматы (7273)495-231
Ангарск (3955)60-70-56
Архангельск (8182)63-90-72
Астрахань (8512)99-46-04
Барнаул (3852)73-04-60
Белгород (4722)40-23-64
Благовещенск (4162)22-76-07
Брянск (4832)59-03-52
Владивосток (423)249-28-31
Владикавказ (8672)28-90-48
Владимир (4922)49-43-18
Волгоград (844)278-03-48
Вологда (8172)26-41-59
Воронеж (473)204-51-73
Екатеринбург (343)384-55-89
Иваново (4932)77-34-06
Ижевск (3412)26-03-58
Иркутск (395)279-98-46
Казань (843)206-01-48

Калининград (4012)72-03-81
Калуга (4842)92-23-67
Кемерово (3842)65-04-62
Киров (8332)68-02-04
Коломна (4966)23-41-49
Кострома (4942)77-07-48
Краснодар (861)203-40-90
Красноярск (391)204-63-61
Курск (4712)77-13-04
Курган (3522)50-90-47
Липецк (4742)52-20-81
Магнитогорск (3519)55-03-13
Москва (495)268-04-70
Мурманск (8152)59-64-93
Набережные Челны (8552)20-53-41
Нижний Новгород (831)429-08-12
Новокузнецк (3843)20-46-81
Ноябрьск (3496)41-32-12
Новосибирск (383)227-86-73
Киргизия (996)312-96-26-47

Омск (3812)21-46-40
Орел (4862)44-53-42
Оренбург (3532)37-68-04
Пенза (8412)22-31-16
Петрозаводск (8142)55-98-37
Псков (8112)59-10-37
Пермь (342)205-81-47
Ростов-на-Дону (863)308-18-15
Рязань (4912)46-61-64
Самара (846)206-03-16
Саранск (8342)22-96-24
Санкт-Петербург (812)309-46-40
Саратов (845)249-38-78
Севастополь (8692)22-31-93
Симферополь (3652)67-13-56
Смоленск (4812)29-41-54
Сочи (862)225-72-31
Ставрополь (8652)20-65-13
Сургут (3462)77-98-35
Россия (495)268-04-70

Сыктывкар (8212)25-95-17
Тамбов (4752)50-40-97
Тверь (4822)63-31-35
Тольятти (8482)63-91-07
Томск (3822)98-41-53
Тула (4872)33-79-87
Тюмень (3452)66-21-18
Ульяновск (8422)24-23-59
Улан-Удэ (3012)59-97-51
Уфа (347)229-48-12
Хабаровск (4212)92-98-04
Чебоксары (8352)28-53-07
Челябинск (351)202-03-61
Череповец (8202)49-02-64
Чита (3022)38-34-83
Якутск (4112)23-90-97
Ярославль (4852)69-52-93
Казахстан (772)734-952-31