

Алматы (7273)495-231
Ангарск (3955)60-70-56
Архангельск (8182)63-90-72
Астрахань (8512)99-46-04
Барнаул (3852)73-04-60
Белгород (4722)40-23-64
Благовещенск (4162)22-76-07
Брянск (4832)59-03-52
Владивосток (423)249-28-31
Владикавказ (8672)28-90-48
Владимир (4922)49-03-18
Волгоград (844)278-03-48
Вологда (8172)26-41-59
Воронеж (473)204-51-73
Екатеринбург (343)384-55-89
Иваново (4932)77-34-06
Ижевск (3412)26-03-58
Иркутск (395)279-98-46
Казань (843)206-01-48

Калининград (4012)72-03-81
Калуга (4842)92-23-67
Кемерово (3842)65-04-62
Киров (8332)68-02-04
Коломна (4966)23-41-49
Кострома (4942)77-07-48
Краснодар (861)203-40-90
Красноярск (391)204-63-61
Курск (4712)77-13-04
Курган (3522)50-90-47
Липецк (4742)52-20-81
Магнитогорск (3519)55-03-13
Москва (495)268-04-70
Мурманск (8152)59-64-93
Набережные Челны (8552)20-53-41
Нижний Новгород (831)429-08-12
Новокузнецк (3843)20-46-81
Ноябрьск (3496)41-32-12
Новосибирск (383)227-86-73
Киргизия (996)312-96-26-47

Омск (3812)21-46-40
Орел (4862)44-53-42
Оренбург (3532)37-68-04
Пенза (8412)22-31-16
Петрозаводск (8142)55-98-37
Псков (8112)59-10-37
Пермь (342)205-81-47
Ростов-на-Дону (863)308-18-15
Курск (4712)77-13-04
Самара (846)206-03-16
Саранск (8342)22-96-24
Санкт-Петербург (812)309-46-40
Саратов (845)249-38-78
Севастополь (8692)22-31-93
Симферополь (3652)67-13-56
Смоленск (4812)29-41-54
Сочи (862)225-72-31
Ставрополь (8652)20-65-13
Сургут (3462)77-98-35
Россия (495)268-04-70

Сыктывкар (8212)25-95-17
Тамбов (4752)50-40-97
Тверь (4822)63-31-35
Тольятти (8482)63-91-07
Томск (3822)98-41-53
Тула (4872)33-79-87
Тюмень (3452)66-21-18
Ульяновск (8422)24-23-59
Улан-Удэ (3012)59-97-51
Уфа (347)229-48-12
Хабаровск (4212)92-98-04
Чебоксары (8352)28-53-07
Челябинск (351)202-03-61
Череповец (8202)49-02-64
Чита (3022)38-34-83
Якутск (4112)23-90-97
Ярославль (4852)69-52-93
Казахстан (772)734-952-31

Electric Pedestrian Pallet Stacker KMS.AC 1500/2,5

Standard equipment:

- Heavy-duty application
- Max. travel speed - 6,0 km/h
- Capacity - 1500 kg
- Lifting height - 2,5 m
- AC drive motor - 1,3 kW:
 - Maintenance free
 - External Encoder
 - Low noise level
- DC pump motor - 3,2 kW
- Speed control by pulse controller COMBI AC/250A including regenerative braking with energy reclamation to the battery
- Electronics - modern CANBUS-architecture requiring less wiring, giving better reliability, providing easy and fast diagnostics
- Horn
- Automatic Braking:
 - EMERGENCY and PARKING electromagnetic brake
 - REGENERATIVE Braking when releasing Accelerator in a neutral position or reversing the travel direction
- Traction battery 24V 2PzS/250Ah C5 (wet Pb Acid batteries)
- High frequency/HF automatic On-board Charger 24V/30A 1 ph.
- EMERGENCY Switch
- Multifunctional Digital Indicator displaying:
 - Battery's state of charge
 - Hour meter
 - Alarms
 - 3 factory preselected Driving Modes (SPD HI / SPD MID / SPD LO)
 - 3 factory preselected Lifting/Lowering Modes (HYD SFT / HYD MID / HYD HRD)
- Proportional hydraulics for smooth, step less Lifting/Lowering speed control
- Rollers and wheels - Polyurethane. Load side - Tandem rollers as standard
- Two castor wheels (left and right Driver side) and Spring loaded Drive Wheel in the middle
- CREEP SPEED function - travelling in restricted areas with Tiller-arm in upright position
- Automatic Travel speed reduction when forks raised 600 mm and more
- Two-stage mast with central cylinder
- Virtually maintenance-free Drive-wheel unit:
 - Modern AC traction motor in vertical position
 - High efficient gear box /gears in oil bath - no oil change required for life
 - High quality Traction wheel with Polyurethane, 93° Shore A tyre (other tyres available on request)
 - High quality Electromagnetic Brake with environment-friendly friction lining

Optional equipment:

- Batteries with higher capacity:
 - 24V 3PzS/315 Ah C5, incl. charger 24V/45A 1 ph.
 - 24V 3PzS/375 Ah C5, incl. charger 24V/45A 1 ph.
- Automatically foldable stand-on Platform, mid driver-side
- Manually foldable Side-protection arms
- Authorised access with PIN Code management
- Traction motor AC 1,5 kW
- Package EPS/Electric Powered Steering (including - EPS Transmission 1,3 kW + Mechanical Interface + Steering Controller + Sensors + Wiring + Integration)
Note: EPS is a system to provide FATIGUE-FREE (thus driver-friendly) and safe steering by means of electrical front-axle steering and Curve control
- Package HS for travel speed 10,0 km/h (including Automatically foldable stand-on Platform, Manually foldable Side-protection arms, Package EPS with Transmission 2,9 kW)
- Initial lift
- Sideways battery removal in a multi-shift applications (roller bed)
- Trolley for batteries side removal (with roller beds for 2 batteries)
- Straddle legs incl. Fork carriage ISO/FEM Class 2B and forks 40/100/1200mm
- Freezer application (working in cold storage rooms with temperature up to -25°C)
- Maintenance-free batteries HAWKER (GEL or NexSys)
- Li-Ion maintenance-free batteries MIDAC

Electric Pedestrian Pallet Stacker KMS.AC 1500/2,5

Type sheet for industrial Trucks according to VDI 2198

Characteristics	1.1	Manufacturer			VENI
	1.2	Manufacturer's type designation			KMS.AC 1500/2,5
	1.3	Power unit			Battery
	1.4	Operation			Pedestrian
	1.5	Load capacity	Q	(kg)	1500
	1.51	Residual capacity	Q_{res}	-	-
		$h_3+h_{13} = 2000$ mm	-	(kg)	1500
		$h_3+h_{13} = 2500$ mm	-	(kg)	1300
	1.6	Load centre	c	(mm)	600
	1.8	Axle centre to fork face	x	(mm)	690
1.9	Wheelbase	y	(mm)	1256	
Weight	2.1	Service weight incl. battery		(kg)	910
Wheels/tyres	3.1	Tyres front/rear (Polyurethane/PU, Vulkollan/VU)			PU/PU
	3.2	Tyre size, front		(mm)	D 230x70
	3.3	Tyre size, rear		(mm)	D 85x70
	3.4	Support wheels		(mm)	D 150x50
	3.5	Wheels, number front / rear (x=driven)		(mm)	1x+2/4
	3.6	Track width, front	b₁₀	(mm)	720
	3.7	Track width, rear	b₁₁	(mm)	410
Dimensions	4.2	Height, mast lowered	h₁	(mm)	1750
	4.3	Free lift	h₂	(mm)	100
	4.4	Lift	h₃	(mm)	2410
	4.5	Height, mast extended	h₄	(mm)	2905
	4.9	Height of tiller in drive position min./max.	h₁₄	(mm)	1200/1310
	4.15	Fork height, lowered	h₁₃	(mm)	90
	4.151	Fork height, lifted	h₃+h₁₃	(mm)	2500
	4.19	Overall length	l₁	(mm)	1906
	4.20	Length to fork face	l₂	(mm)	756
	4.21	Overall width	b₁	(mm)	866
	4.22	Fork dimensions	s/e/l	(mm)	55/175/1150
	4.25	Overall forks width	b₅	(mm)	570
	4.32	Ground clearance, centre of wheelbase	m₂	(mm)	30
	4.34	Aisle width with pallet 800x1200 mm along forks	A_{st}	(mm)	2294
4.35	Turning radius	W_a	(mm)	1446	
Performance	5.1	Travel speed, with/ without load		(km/h)	5.4/6.0
	5.2	Lifting speed, with/ without load		(m/s)	0.136/0.230
	5.3	Lowering speed, with/ without load		(m/s)	0.238/0.250
	5.8	Maximum gradeability, with/ without load		(%)	7/15
	5.10	Service brake			Electromagnetic
Drive	6.1	Drive motor, rating S2 60 min		(kW)	1.3
	6.2	Lift motor rating S3 15%		(kW)	3.2
	6.4	Battery voltage/ rated capacity C5		(V/Ah)	24/250
Others	8.1	Type of drive control			Pulse controller COMBI AC/250A

KMS.AC 1500/2,5

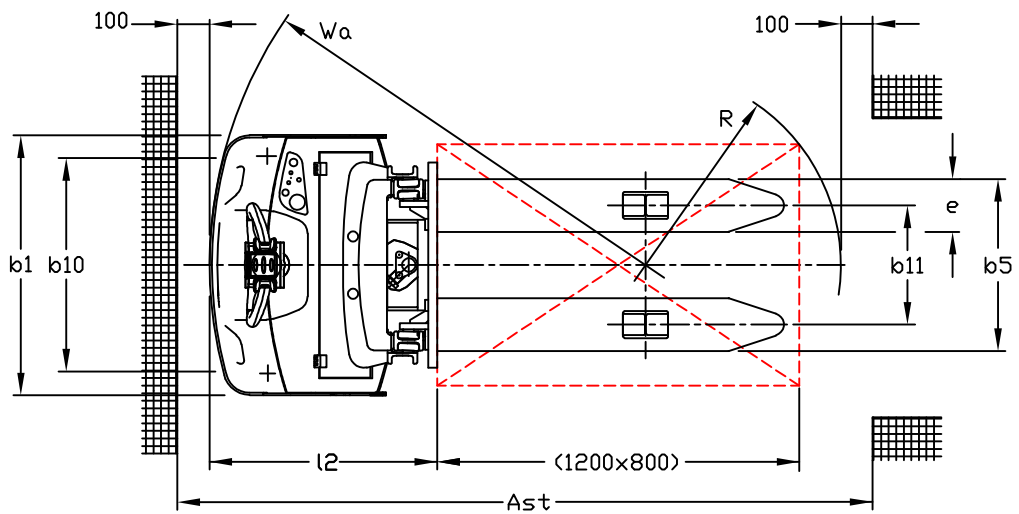
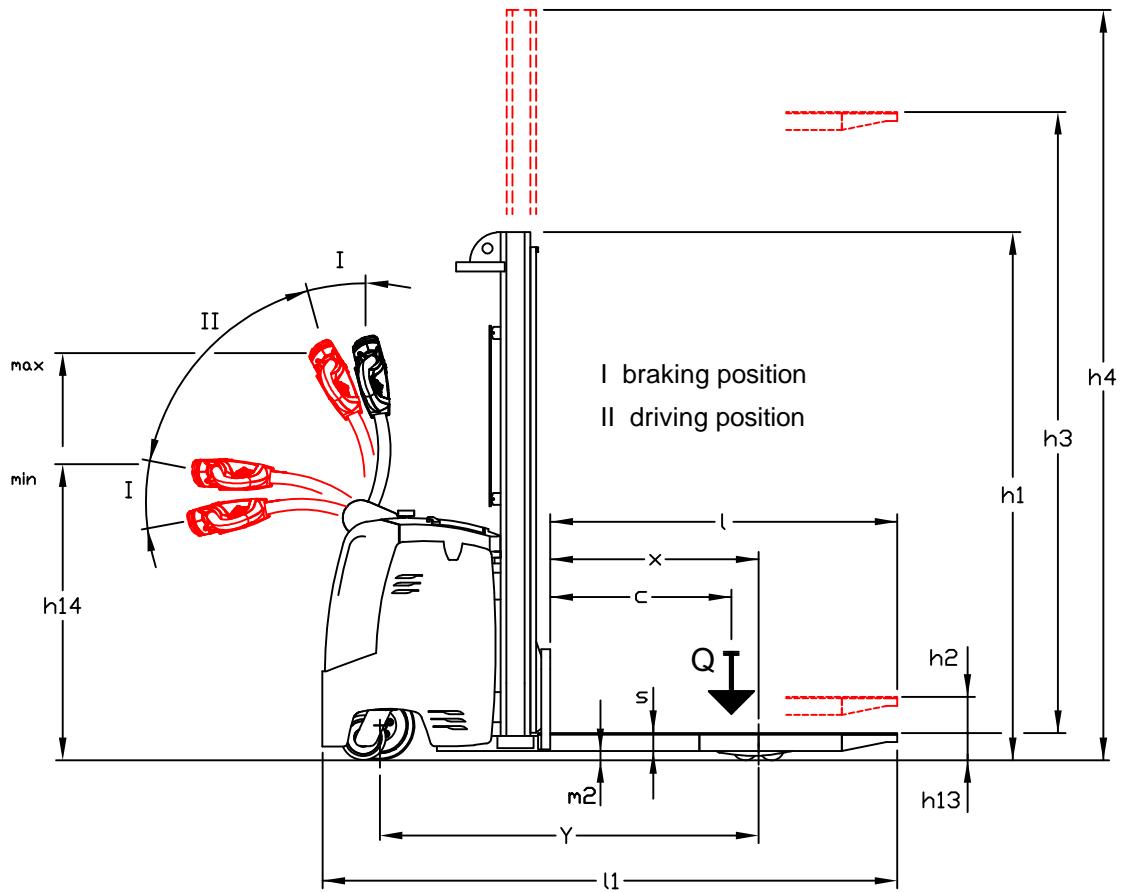

Алматы (7273)495-231
Ангарск (3955)60-70-56
Архангельск (8182)63-90-72
Астрахань (8512)99-46-04
Барнаул (3852)73-04-60
Белгород (4722)40-23-64
Благовещенск (4162)22-76-07
Брянск (4832)59-03-52
Владивосток (423)249-28-31
Владикавказ (8672)28-90-48
Владимир (4922)49-43-18
Волгоград (844)278-03-48
Вологда (8172)26-41-59
Воронеж (473)204-51-73
Екатеринбург (343)384-55-89
Иваново (4932)77-34-06
Ижевск (3412)26-03-58
Иркутск (395)279-98-46
Казань (843)206-01-48

Калининград (4012)72-03-81
Калуга (4842)92-23-67
Кемерово (3842)65-04-62
Киров (8332)68-02-04
Коломна (4966)23-41-49
Кострома (4942)77-07-48
Краснодар (861)203-40-90
Красноярск (391)204-63-61
Курск (4712)77-13-04
Курган (3522)50-90-47
Липецк (4742)52-20-81
Магнитогорск (3519)55-03-13
Москва (495)268-04-70
Мурманск (8152)59-64-93
Набережные Челны (8552)20-53-41
Нижний Новгород (831)429-08-12
Новокузнецк (3843)20-46-81
Ноябрьск (3496)41-32-12
Новосибирск (383)227-86-73
Киргизия (996)312-96-26-47

Омск (3812)21-46-40
Орел (4862)44-53-42
Оренбург (3532)37-68-04
Пенза (8412)22-31-16
Петрозаводск (8142)55-98-37
Псков (8112)59-10-37
Пермь (342)205-81-47
Ростов-на-Дону (863)308-18-15
Рязань (4912)46-61-64
Самара (846)206-03-16
Саранск (8342)22-96-24
Санкт-Петербург (812)309-46-40
Саратов (845)249-38-78
Севастополь (8692)22-31-93
Симферополь (3652)67-13-56
Смоленск (4812)29-41-54
Сочи (862)225-72-31
Ставрополь (8652)20-65-13
Сургут (3462)77-98-35
Россия (495)268-04-70

Сыктывкар (8212)25-95-17
Тамбов (4752)50-40-97
Тверь (4822)63-31-35
Тольятти (8482)63-91-07
Томск (3822)98-41-53
Тула (4872)33-79-87
Тюмень (3452)66-21-18
Ульяновск (8422)24-23-59
Улан-Удэ (3012)59-97-51
Уфа (347)229-48-12
Хабаровск (4212)92-98-04
Чебоксары (8352)28-53-07
Челябинск (351)202-03-61
Череповец (8202)49-02-64
Чита (3022)38-34-83
Якутск (4112)23-90-97
Ярославль (4852)69-52-93
Казахстан (772)734-952-31