

Алматы (7273)495-231  
 Ангарск (3955)60-70-56  
 Архангельск (8182)63-90-72  
 Астрахань (8512)99-46-04  
 Барнаул (3852)73-04-60  
 Белгород (4722)40-23-64  
 Благовещенск (4162)22-76-07  
 Брянск (4832)59-03-52  
 Владивосток (423)249-28-31  
 Владикавказ (8672)28-90-48  
 Владимир (4922)49-43-18  
 Волгоград (844)278-03-48  
 Вологда (8172)26-41-59  
 Воронеж (473)204-51-73  
 Екатеринбург (343)384-55-89  
 Иваново (4932)77-34-06  
 Ижевск (3412)26-03-58  
 Иркутск (395)279-98-46  
 Казань (843)206-01-48

Калининград (4012)72-03-81  
 Калуга (4842)92-23-67  
 Кемерово (3842)65-04-62  
 Киров (8332)68-02-04  
 Коломна (4966)23-41-49  
 Кострома (4942)77-07-48  
 Краснодар (861)203-40-90  
 Красноярск (391)204-63-61  
 Курск (4712)77-13-04  
 Курган (3522)50-90-47  
 Липецк (4742)52-20-81  
 Магнитогорск (3519)55-03-13  
 Москва (495)268-04-70  
 Мурманск (8152)59-64-93  
 Набережные Челны (8552)20-53-41  
 Нижний Новгород (831)429-08-12  
 Новокузнецк (3843)20-46-81  
 Ноябрьск (3496)41-32-12  
 Новосибирск (383)227-86-73  
 Киргизия (996)312-96-26-47

Омск (3812)21-46-40  
 Орел (4862)44-53-42  
 Оренбург (3532)37-68-04  
 Пенза (8412)22-31-16  
 Петрозаводск (8142)55-98-37  
 Псков (8112)59-10-37  
 Пермь (342)205-81-47  
 Ростов-на-Дону (863)308-18-15  
 Рязань (4912)46-61-64  
 Самара (846)206-03-16  
 Саранск (8342)22-96-24  
 Санкт-Петербург (812)309-46-40  
 Саратов (845)249-38-78  
 Севастополь (8692)22-31-93  
 Симферополь (3652)67-13-56  
 Смоленск (4812)29-41-54  
 Сочи (862)225-72-31  
 Ставрополь (8652)20-65-13  
 Сургут (3462)77-98-35  
 Россия (495)268-04-70

Сыктывкар (8212)25-95-17  
 Тамбов (4752)50-40-97  
 Тверь (4822)63-31-35  
 Тольятти (8482)63-91-07  
 Томск (3822)98-41-53  
 Тула (4872)33-79-87  
 Тюмень (3452)66-21-18  
 Ульяновск (8422)24-23-59  
 Улан-Удэ (3012)59-97-51  
 Уфа (347)229-48-12  
 Хабаровск (4212)92-98-04  
 Чебоксары (8352)28-53-07  
 Челябинск (351)202-03-61  
 Череповец (8202)49-02-64  
 Чита (3022)38-34-83  
 Якутск (4112)23-90-97  
 Ярославль (4852)69-52-93  
 Казахстан (772)734-952-31

## Electric Pedestrian Pallet Stacker KMSac.4W 16xxxx TT

### Type sheet for industrial Trucks according to VDI 2198

Characteristics				Veni and Co Ltd					
				164416 TT	164920 TT	165727 TT			
Characteristics	1.1	Manufacturer			Battery				
	1.2	Model designation			Pedestrian				
	1.3	Power unit			1600				
	1.4	Operation							
	1.5	Load capacity	Q	(kg)	1600				
	1.5.1	Residual capacity	Qres	-	-	-	-		
				$h_3+h_{13} = 3300 / 3300^* / 3300^{**}$ mm	-	(kg)	1600	1600*	1600**
				$h_3+h_{13} = 4476 / 4980^* / 5787^{**}$ mm	-	(kg)	1200	1100*	960**
	1.6	Load center	c	(mm)	600				
1.8	Axle center to fork face	x	(mm)	760					
1.9	Wheel-base	y	(mm)	1450					
Wheels/tyres	2.1	Service weight		(kg)	1420	1450	1510		
	3.1	Tyres front/rear (Polyurethane/PU, Vulkollan/VU)			VU/VU				
	3.2	Tyre size, front (drive) wheel		(mm)	D 254x100				
	3.3	Tyre size, rear (load) wheel		(mm)	D 150x50 Twin				
	3.4	Support wheel - 2 pcs.		(mm)	-				
	3.5	Wheels, number front (drive)/ rear (load) (x=driven)		(mm)	1x/4				
	3.6	Track width, front	b <sub>10</sub>	(mm)	-				
3.7	Track width, rear	b <sub>11</sub>	(mm)	1130-1530-1830					
Dimensions	4.2	Height, mast lowered	h <sub>1</sub>	(mm)	2072	2240	2509		
	4.3	Free lift	h <sub>2</sub>	(mm)	105				
	4.4	Lift	h <sub>3</sub>	(mm)	4416	4920	5727		
	4.5	Height, mast extended	h <sub>4</sub>	(mm)	4946	5450	6257		
	4.9	Height of tiller in drive position min/max	h <sub>14</sub>	(mm)	1320/1500				
	4.10	Height of wheel arms	h <sub>8</sub>	(mm)	280				
	4.15	Height lowered	h <sub>13</sub>	(mm)	60				
	4.15.1	Height forks lifted	h <sub>3</sub> +h <sub>13</sub>	(mm)	4476	4980	5787		
	4.19	Overall length	l <sub>1</sub>	(mm)	2087				
	4.20	Length to fork face	l <sub>2</sub>	(mm)	887				
	4.21	Overall width front	b <sub>1</sub>	(mm)	866				
			b <sub>2</sub>	(mm)	1395-1795-2095				
	4.22	Fork dimensions	s/e/l	(mm)	45/120/1200				
	4.23	Fork carriage ISO 2328	-	-	Class2B				
	4.24	Fork carriage width	b <sub>3</sub>	(mm)	900-1300-1600				
	4.25	Overall forks width min/max	b <sub>5</sub>	(mm)	300/860-1260-1560				
4.26	Distance between wheel arms	b <sub>4</sub>	(mm)	950-1350-1650					
4.31	Ground clearance, below mast	m <sub>1</sub>	(mm)	60					
4.32	Ground clearance, center of wheelbase	m <sub>2</sub>	(mm)	80					
4.34	Aisle width for pallets 800x1200mm along forks	Ast	(mm)	-					
		Ast	(mm)	-					
4.35	Aisle width for pallets 800x1200mm across forks	Wa	(mm)	1647					
4.37	Turning radius	l <sub>7</sub>	(mm)	1792					
Performance	5.1	Travel speed, with/without load		(km/h)	5.4/6.0				
	5.2	Lifting speed, with/without load		(m/s)	0.134/0.250				
	5.3	Lowering speed, with/without load		(m/s)	0.215/0.230				
	5.8	Maximum climbing ability, with/without load, rating 5 min		(%)	-				
	5.10	Service brake			Electromagnetic, regenerative				
Drive	6.1	Drive motor, rating S2 60 min		(kW)	2.9				
	6.2	Lift motor, rating S3 15%		(kW)	3.2				
	6.4	Battery voltage/rated capacity C5		(V/Ah)	24/315				
Other	8.1	Type of drive control			Pulse controller				
					COMBI AC/300A				

# KMSac.4W 16xxxx TT

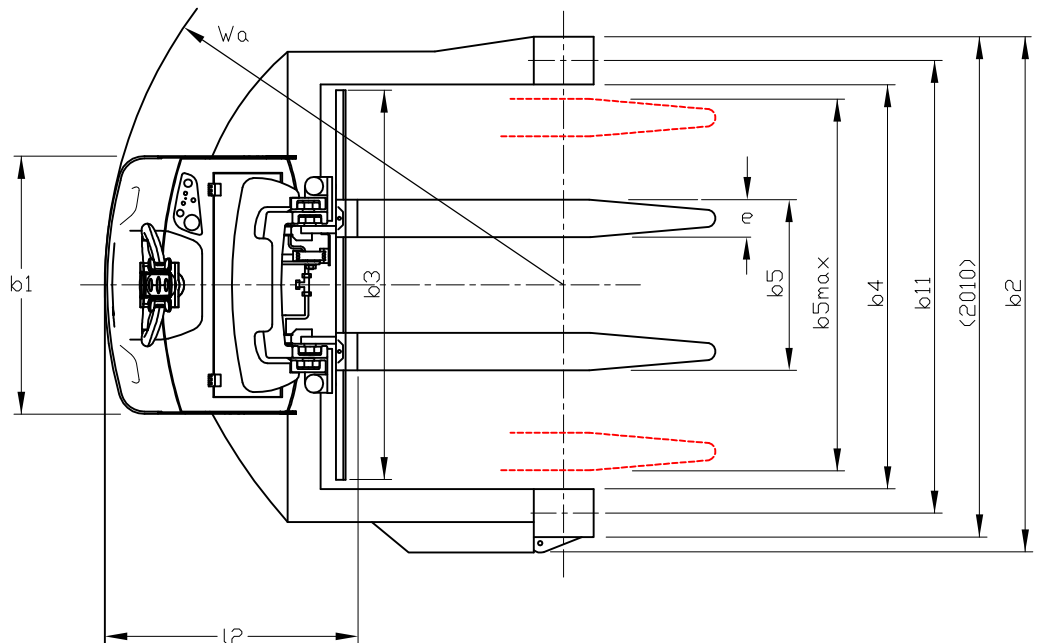
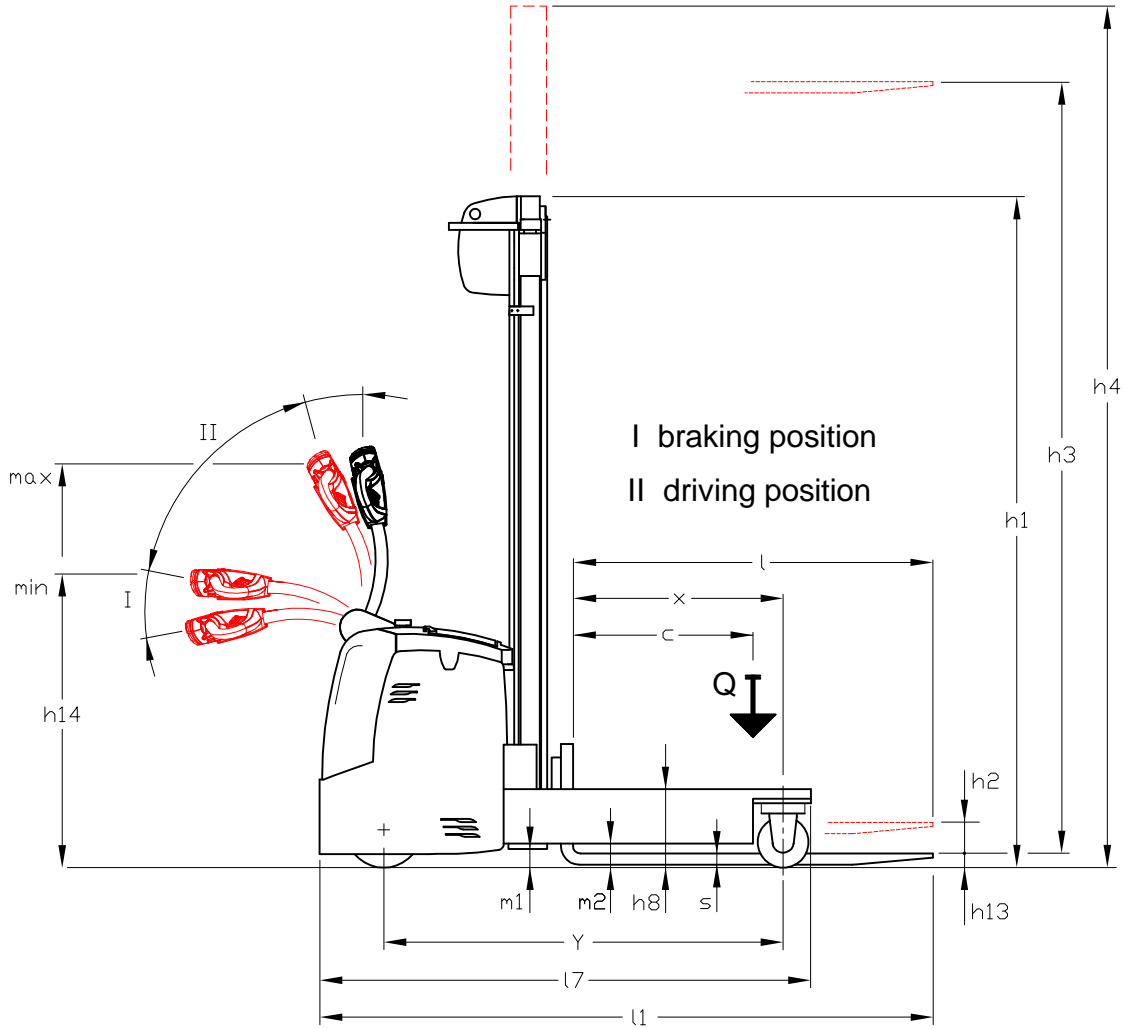

# Electric Pedestrian Pallet 4-way Stacker KMSac 16xxxx TT

## Standard equipment:

- Mid to Heavy-duty application
- Max. travel speed - 6,0 km/h
- Nominal capacity – 1600 kg
- **Modern AC technology** - for high speed, high torque, quiet and smooth running;
  - AC Drive motor - **2,9 kW**;
  - AC Steering motor - **0,4 kW**.
- **DC pump motor – 3,2 kW**;
- Electronics - modern **CANBUS-architecture** requiring less wiring, giving better reliability, providing easy and fast diagnostics;
- **Electric Powered progressive Steering**;
- Speed control by **Pulse controller COMBI AC/300A**:
  - smooth and gently running Forward/Backward;
  - smooth, step-less Lifting/Lowering;
  - regenerative braking with energy reclamation to the battery.
- Electronics - modern **CANBUS-architecture** requiring less wiring, giving better reliability, providing easy and fast diagnostics;
- Horn
- Automatic Braking:
  - EMERGENCY and PARKING electromagnetic brake
  - REGENERATIVE Braking when releasing Accelerator in a neutral position or reversing the travel direction
- Traction battery **24V 3PzS/315 Ah C5 / wet Pb Acid batteries**:
- High frequency/HF automatic on-board charger **24V/45A 1ph.**:
- EMERGENCY Switch
- Multifunction Digital Indicator displaying:
  - Battery's state of charge
  - Hour meter
  - Alarms
- **Proportional hydraulics for smooth, step less Lifting/Lowering speed control**
- **External Battery-charging Indicator**;
- Spring loaded Drive wheel;
- Traction wheel – VULKOLLAN tire 254x100mm;
- Support / Load wheels – VULKOLLAN tire;
- **CREEP SPEED** function – travelling in restricted areas with Tiller-arm in upright position
- Automatic Travel speed reduction when forks raised 1200 mm and more
- Robust Three-stage clear view mast / Triplex Telescopic
- Low-maintenance Drive-wheel unit:
  - Modern AC traction motor in vertical position
  - High efficient gear box /gears in oil bath - oil change required after 2000 working hours
  - High quality Traction wheel with VULKOLLAN, 93° Shore A tyre (other tyres available on request)
  - High quality Electromagnetic Brake with environment-friendly friction lining

## Specific standard equipment:

- **Chassis design – Straddle legs**
- **Distance between the wheel arms “b4=950mm” - Standard (1350 and 1650mm - Optional)**
- **Specific Load wheels**;
- **Fork carriage class 2B, ISO 2328, Carriage width “b3=900mm” - Standard (1300 and 1600 – Optional)**
- **Forged forks 45/120/1200mm, manually adjustable Overall forks width “b5= from 300 to 860” – Standard (1260 and 1560mm).**

## Optional Equipment

- Batteries with higher capacity:
  - 375 Ah C5, incl. charger 24V/45A plus 145 € -
  - 420 Ah C5, incl. external charger 24V/60A plus 553 € -
- **Authorized access with PIN-Code management** plus 174 €
- **Full Free-lift mast** plus 380 €
- **Optional Straddle legs distance**:
  - “b4=1350mm” plus 186 € -
  - “b4=1650mm” plus 247 € -
- Maintenance-free batteries by request -

<https://veni.nt-rt.ru> || [vni@nt-rt.ru](mailto:vni@nt-rt.ru)

Алматы (7273)495-231  
Ангарск (3955)60-70-56  
Архангельск (8182)63-90-72  
Астрахань (8512)99-46-04  
Барнаул (3852)73-04-60  
Белгород (4722)40-23-64  
Благовещенск (4162)22-76-07  
Брянск (4832)59-03-52  
Владивосток (423)249-28-31  
Владикавказ (8672)28-90-48  
Владимир (4922)49-43-18  
Волгоград (844)278-03-48  
Вологда (8172)26-41-59  
Воронеж (473)204-51-73  
Екатеринбург (343)384-55-89  
Иваново (4932)77-34-06  
Ижевск (3412)26-03-58  
Иркутск (395)279-98-46  
Казань (843)206-01-48

Калининград (4012)72-03-81  
Калуга (4842)92-23-67  
Кемерово (3842)65-04-62  
Киров (8332)68-02-04  
Коломна (4966)23-41-49  
Кострома (4942)77-07-48  
Краснодар (861)203-40-90  
Красноярск (391)204-63-61  
Курск (4712)77-13-04  
Курган (3522)50-90-47  
Липецк (4742)52-20-81  
Магнитогорск (3519)55-03-13  
Москва (495)268-04-70  
Мурманск (8152)59-64-93  
Набережные Челны (8552)20-53-41  
Нижний Новгород (831)429-08-12  
Новокузнецк (3843)20-46-81  
Ноябрьск (3496)41-32-12  
Новосибирск (383)227-86-73  
Киргизия (996)312-96-26-47

Омск (3812)21-46-40  
Орел (4862)44-53-42  
Оренбург (3532)37-68-04  
Пенза (8412)22-31-16  
Петрозаводск (8142)55-98-37  
Псков (8112)59-10-37  
Пермь (342)205-81-47  
Ростов-на-Дону (863)308-18-15  
Рязань (4912)46-61-64  
Самара (846)206-03-16  
Саранск (8342)22-96-24  
Санкт-Петербург (812)309-46-40  
Саратов (845)249-38-78  
Севастополь (8692)22-31-93  
Симферополь (3652)67-13-56  
Смоленск (4812)29-41-54  
Сочи (862)225-72-31  
Ставрополь (8652)20-65-13  
Сургут (3462)77-98-35  
Россия (495)268-04-70

Сыктывкар (8212)25-95-17  
Тамбов (4752)50-40-97  
Тверь (4822)63-31-35  
Тольятти (8482)63-91-07  
Томск (3822)98-41-53  
Тула (4872)33-79-87  
Тюмень (3452)66-21-18  
Ульяновск (8422)24-23-59  
Улан-Удэ (3012)59-97-51  
Уфа (347)229-48-12  
Хабаровск (4212)92-98-04  
Чебоксары (8352)28-53-07  
Челябинск (351)202-03-61  
Череповец (8202)49-02-64  
Чита (3022)38-34-83  
Якутск (4112)23-90-97  
Ярославль (4852)69-52-93  
Казахстан (772)734-952-31